

# Nicrofer® 6020 hMo - alloy 625

Material Data Sheet No. 4018  
August 2007 Edition

**Corrosion-resistant and high-temperature alloy**

® 6020 - alloy 625

Nicrofer® 6020 h

20 hMo

Nicrofer® 6020 hMo

625

Nicrofer® 6020 hMo - alloy 625

Nicro

**QUEENSLAND AGENT:**

**Isolthermics Australia Pty Ltd**

**Phone: 07 3245 5561**

**Fax: 07 3245 4753**

**Email: [info@isolthermics.com.au](mailto:info@isolthermics.com.au)**

**Web: [www.isolthermics.com.au](http://www.isolthermics.com.au)**

A company of  
ThyssenKrupp  
Stainless

**ThyssenKrupp VDM**



**ThyssenKrupp**

# Nicrofer® 6020 hMo – alloy 625

Nicrofer 6020 hMo is a low-carbon ( $\leq 0.03\%$ ) nickel-chromium-molybdenum-niobium alloy which shows excellent resistance to a variety of corrosive media.

Due to its low carbon content and stabilizing heat treatment, Nicrofer 6020 hMo shows little tendency to sensitization even after 50 hours at temperatures in the range 650 – 900 °C (1200 – 1650 °F). Also refer to remarks under ‘Heat treatment’.

The alloy is supplied in the soft-annealed condition for applications involving wet corrosion conditions at service temperatures up to 593° C (1100° F) (alloy 625, grade 1), and is approved in this condition by TÜV for pressure vessels in the temperature range -196 to 450 °C (-321 to 840 °F).

For high-temperature applications, above approx. 600 °C ( $\approx 1100$  °F), where high strength and resistance to creep and rupture are required, a solution-annealed version (alloy 625, grade 2) with preferably a slightly higher carbon content

(0.03 – 0.10 %) is occasionally employed and may be available on request in product forms other than strip.

The mechanical properties of Nicrofer 6020 hMo can be slightly increased by age-hardening.

Nicrofer 6020 hMo, grade 1 is characterized by:

- outstanding resistance to pitting, crevice corrosion, erosion and intergranular attack
- almost complete freedom from chloride-induced stress-corrosion cracking
- good resistance to mineral acids, such as nitric, phosphoric, sulfuric and hydrochloric acids
- good resistance to alkalis and organic acids
- good mechanical properties

## Designations and standards

Country	Material designation	Specification								
		Chemical composition	Tube and pipe		Sheet and plate	Rod and bar	Strip	Wire	Forgings	Fittings
			seamless	welded						
D DIN EN DIN VdTÜV	W.-Nr. 2.4856 NiCr22Mo9Nb	10095 17744 499	17751 499 <sup>1)</sup>		10095 <sup>1)</sup> 17750 499 <sup>1)</sup>	10095 <sup>1)</sup> 17752 499 <sup>1)</sup>	10095 <sup>1)</sup> 17750 499 <sup>1)</sup>	10095 <sup>1)</sup> 17753	499 <sup>1)</sup>	
F AFNOR	NC 22 DNb									
UK BS	NA 21		3074		3072	3076				
USA ASTM ASME ASME Code Case AMS	UNS N06625, grade 1		B 444 SB-444 1935 <sup>1)</sup> 5581 <sup>1)</sup>	B 704/705 B 751 SB-704/705 SB-751 5581 <sup>1)</sup>	B 443 SB-443 1935 <sup>1)</sup> 5599 <sup>1)</sup> 5869 <sup>2)</sup>	B 446 SB-446 1935 <sup>1)</sup> 5666 <sup>1)</sup>	B 443 SB-443 1935 <sup>1)</sup> 5599 <sup>1)</sup> 5869 <sup>2)</sup>	5837 <sup>3)</sup>	B 564 SB-564 1935 <sup>1)</sup> 5666 <sup>1)</sup>	B 366
ISO	NiCr22Mo9Nb	9722	6207		6208	9723	6208	9724	9725	

<sup>1)</sup>soft-annealed condition (grade 1) only

<sup>2)</sup> solution-annealed condition (grade 2) only.

<sup>3)</sup>welding wire

Table 1 – Designations and standards.

### Chemical composition\*

	Ni	Cr	Fe	C*	Mn	Si	Mo	Co	Al	Ti	Nb + Ta	P	S
min.	58.0	20.0					8.0				3.15		
max.		23.0	5.0	0.10	0.50	0.50	10.0	1.0	0.40	0.40	4.15	0.015	0.015

Some compositional limits (especially C) of other specifications may vary slightly.

\*Note: ThyssenKrupp VDM supplies normally all product forms with a C-content of  $\leq 0.03\%$ .

Table 2 – Chemical composition (wt.-%) according to ASTM.

### Physical properties

Density	8.4 g/cm <sup>3</sup>	0.303 lb/in. <sup>3</sup>
Melting range	1290 – 1350 °C	2350 – 2460 °F
Permeability at 20 °C/68 °F (RT)	1.003	

Temperature (T)		Specific heat		Thermal conductivity		Electrical resistivity		Modulus of elasticity		Coefficient of thermal expansion between room temperature and T	
°C	°F	$\frac{J}{kg \cdot K}$	$\frac{Btu}{lb \cdot ^\circ F}$	$\frac{W}{m \cdot K}$	$\frac{Btu \cdot in.}{ft^2 \cdot h \cdot ^\circ F}$	$\mu\Omega \cdot cm$	$\Omega \cdot circ \text{ mil}$ ft	$\frac{kN}{mm^2}$	10 <sup>3</sup> ksi	$\frac{10^{-6}}{K}$	$\frac{10^{-6}}{^\circ F}$
20	68	415	0.099	9.8	68	128	770	209	30.3		
93	200		0.103		77		782		29.4		7.0
100	212	435		11.2		130		202		12.8	
200	392	460		12.8		132		195		13.1	
204	400		0.110		90		794		28.3		7.3
300	572	480		14.4		133		190		13.4	
316	600		0.116		101		800		27.3		7.5
400	752	505		16.3		135		185		13.7	
427	800		0.122		115		815		26.5		7.6
500	932	525		17.3		136		178		14.1	
538	1000		0.128		126		818		25.4		7.9
600	1112	550		19.3		136		170		14.6	
649	1200		0.134		139		820		24.1		8.3
700	1292	575		21.0		136		162		15.2	
760	1400		0.141		153		818		22.8		8.6
800	1472	600		22.6		136		153		15.8	
871	1600		0.147		167		815		21.0		9.0
900	1652	625		24.6		135		142		16.4	
982	1800		0.154		182		800		18.9		9.4
1000	1832	650		26.7		132		128		17.0	

Table 3 – Typical physical properties at room and elevated temperatures.

# Nicrofer® 6020 hMo – alloy 625

## Mechanical properties

The following properties are applicable to Nicrofer 6020 hMo (grade 1) in the hot or cold formed and soft-annealed condition and in the indicated size ranges.

Specified properties of material outside these size ranges are subject to special enquiry.

Product	Dimensions		Tensile strength $R_m$		Yield strength $R_{p0.2}$		Elongation $A_5^*$ %	Brinell hardness HB
	mm	inches	MPa	ksi	MPa	ksi		
Sheet, strip* cr			830	120	415	60	30	max. 240 (For information only)
Sheet, plate hr	≤ 70	≤ 2.75	760	110	380	55		
Rod, bar	≤ 100	≤ 4	830	120	415	60		
	> 100	> 4	760	110	345	50	25	
Tube, pipe			830	120	415	60	30	

\*Elongation values for strip products are normally determined on an initial gauge length of 50 mm (2 in.). These values are lower, dependent on the alloy, than the corresponding  $A_5$  values by an order of approx. 10%.

Table 4 – Minimum mechanical properties at room temperature of Nicrofer 6020 hMo, grade 1 according to ASTM.

Note: Minimum mechanical properties at room temperature of Nicrofer 6020 hMo, grade 2 (solution-annealed condition) are lower.

Product	Yield strength, $R_{p0.2}$ MPa					Tensile strength, $R_m$ MPa				
	100	200	300	400	450	100	200	300	400	450
Temperature, °C										
Strip, sheet & plate, seamless tube	350	320	300	280	270	740	700	685	670	660
Rod, bar, forgings [thickness: > 160 mm (6.3")]	290	265	260	260	255	600	580	560	543	530

Product	ksi					ksi				
	200	400	600	800	–	200	400	600	800	–
Temperature, °F										
Strip, sheet & plate, seamless tube	51.1	46.1	42.8	37.7	–	108.3	101.8	98.9	96.3	–
Rod, bar, forgings [thickness: > 160 mm (6.3")]	42.4	38.7	37.7	37.4	–	87.5	83.8	80.8	77.9	–

Table 5 – Minimum short-time mechanical properties in the soft-annealed condition (grade 1) at elevated temperatures according to VdTUV Material Data Sheet 499.

## ISO V-notch impact toughness

In accordance to DIN EN 10045 Part 1.

Average values at RT  $a_k$ : ≥ 125 J/cm<sup>2</sup>  
KV: ≥ 100 J

The alloy is subject to loss of impact strength at room temperature after exposure in the range of 1000 °F (538 °C) to 1100 °F (593 °C).



### Metallurgical structure

Nicrofer 6020 hMo has a face-centered-cubic structure. Two versions of the alloy are in use. For wet corrosive service the soft-annealed (often also referred to as stabilized) condition (grade 1) is utilized which incorporates a thermal treatment at 980 °C (1800 °F). For high temperature applications the material is supplied in the solution-annealed condition (grade 2), after a thermal treatment at 1120 °C (2050 °F), with a higher carbon content (approx. 0.05 %) in some product forms.

As a result of the formation of  $Ni_3(Nb, Mo)$  phases the mechanical properties are enhanced through precipitation hardening of the nickel-chromium matrix. However, particularly after long exposures in the temperature range 600 – 900 °C (1100 – 1650 °F) the alloy precipitates some carbides and a metastable tetragonal phase is formed which later changes to a stable orthorhombic phase. This causes a loss in ductility but improves the resistance to intergranular corrosion in the case of the soft-annealed (stabilized) version (grade 1) of Nicrofer 6020 hMo. In case of the solution-annealed version (grade 2) the situation is reversed. Thus in specifying a stabilizing anneal it is important to consider the anticipated service conditions and to select the final thermal treatment accordingly. This means that if intergranular corrosion resistance is of primary concern the stabilizing anneal should be a soft anneal, whereas for applications requiring high ductility a solution anneal should be the final thermal operation as indicated in Fig. 2.

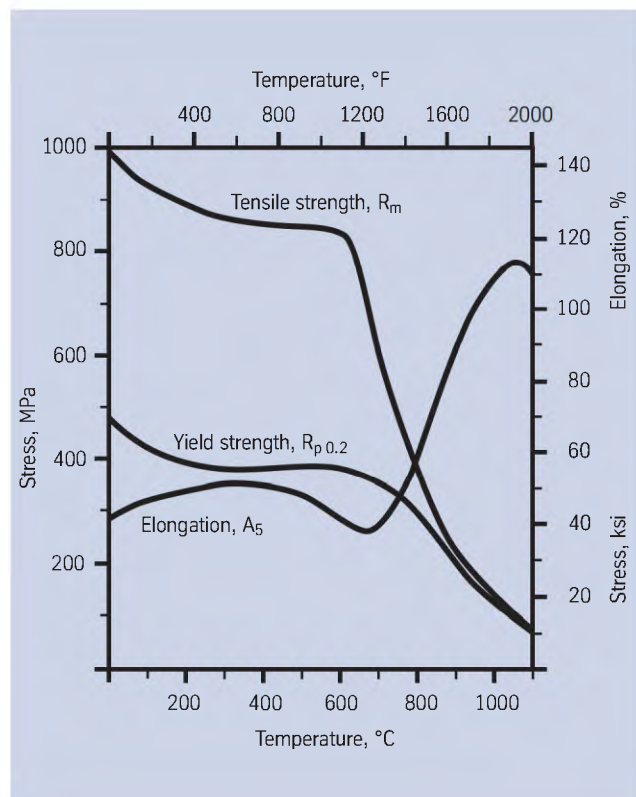

Fig. 1 – Typical short-time mechanical properties at elevated temperatures of cold rolled Nicrofer 6020 hMo annealed at 1000 °C (1830 °F).

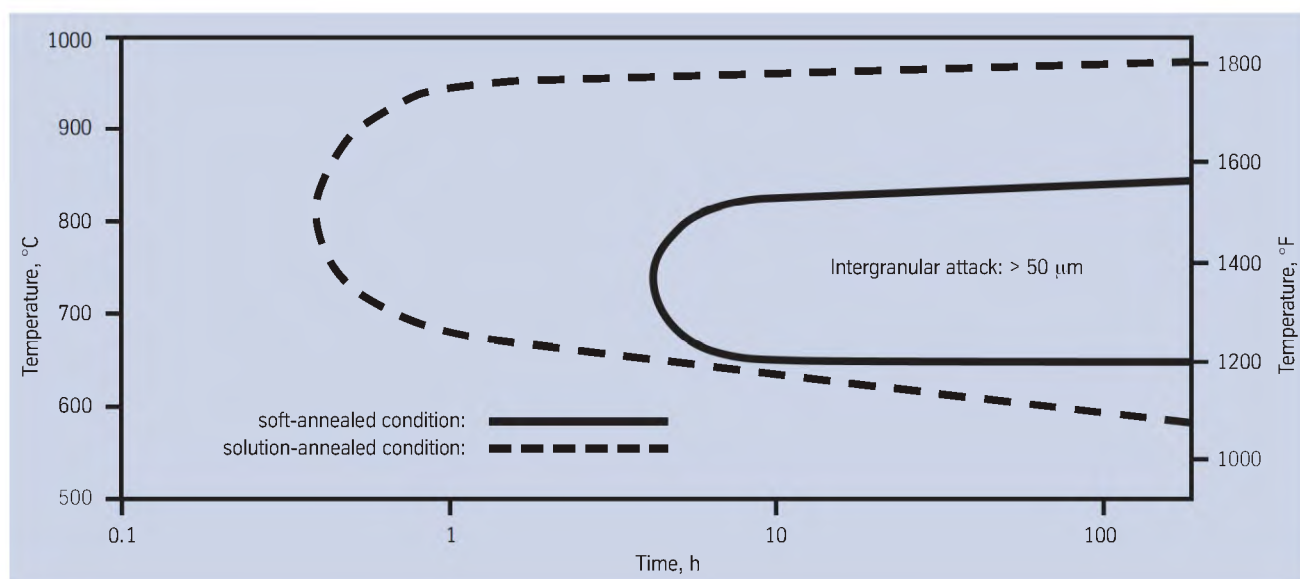

Fig. 2 – Time-Temperature-Sensitization (TTS) diagram for Nicrofer 6020 hMo (0.02 % carbon) according to ASTM G-28 A, (120 h).

### Relaxation cracking susceptibility

Similar to some other high-temperature, high-strength nickel alloys, Nicrofer 6020 hMo may suffer stress relaxation cracking (brittle intergranular failure) in the temperature range 625 – 675 °C (1160 – 1250 °F), especially in cold deformed and/or (repair) welded areas after 1 to 2 years service. In such cases, a stabilize anneal at 980 °C (1800 °F) for 3 hrs (for new and already service exposed material with or

without weldments) is recommended to relieve stresses and deliberately influence precipitation processes. In the case of originally soft-annealed (but not solution-annealed) material which is cold deformed less than 15% and which is not welded this stabilizing anneal is, however, not required. Heating and cooling rates for such heat treatments are not critical.

### Corrosion resistance

For optimal corrosion resistance the material must be in a clean condition and free from all kinds of contaminants before any fabricated component is placed into service. Under these conditions Nicrofer 6020 hMo exhibits excellent corrosion resistance in a wide variety of media:

- excellent resistance to pitting and crevice corrosion in chloride-bearing media
- essentially resistant to chloride-induced stress-corrosion cracking
- high resistance against impingement and erosion corrosion
- high resistance to corrosive attack by mineral acids, such as nitric, phosphoric, sulfuric and hydrochloric acids, as well as to alkalis and organic acids in both oxidizing and reducing conditions

- practically no corrosive attack in marine and industrial atmospheres. High resistance to seawater and brackish water, even at higher temperatures
- high resistance against intergranular corrosion following thermal treatment and welding

The solution-annealed version (grade 2) shows good resistance to many corrosive gas atmospheres:

- good resistance to carburization and to oxidation under static and cyclic conditions; suitable for use in air up to 1000 °C (1830 °F)
- resistance to nitridation
- good resistance to halogen containing gases and to hydrogen chloride

Alloy		CPT		CCT		PRE Pitting Resistance Equivalent
		°C	°F	°C	°F	
316 Ti	(UNS S31635)	15	59	< 0	< 32	24
904 L	(UNS N08904)	45	113	25	77	37
Cronifer 1925 hMo – alloy 926	(UNS N08926)	70	158	40	104	47
Nicrofer 3033 – alloy 33	(UNS R20033)	85	185	40	104	50
<b>Nicrofer 6020 hMo – alloy 625</b>		<b>77.5</b>		<b>57.5</b>		<b>51</b>

PRE = % Cr + 3.3 (% Mo) + 30 (% N)

Table 6 – Critical pitting temperature (CPT) and critical crevice temperature (CCT) of Nicrofer 6020 hMo (grade 1) compared to high-alloyed stainless steels in 10 % FeCl<sub>3</sub> x 6 H<sub>2</sub>O.

### Applications

The soft-annealed version of Nicrofer 6020 hMo (grade 1) is preferred for applications in the chemical process industry, in marine engineering and in pollution control equipment for environmental protection.

Typical applications are:

- superphosphoric acid production equipment
- nuclear waste reprocessing equipment
- sour gas production tubes
- piping systems and sheathing of risers in oil exploration
- offshore industry and marine equipment
- flue gas scrubber and damper components
- chimney linings

For high-temperature applications, up to approximately 1000 °C (1830 °F), the solution-annealed version of alloy 625 (grade 2) can be used in accordance to the ASME code for pressure vessels. For design calculations for equipment for use within the temperature range of approximately 500 – 1000 °C (930 – 1830 °F) the loss in ductility resulting from prolonged exposure within that temperature range must be kept in mind.

Typical applications are:

- components in waste gas systems and waste gas cleaning plants exposed to higher temperatures
- flare stacks in refineries and offshore platforms
- recuperators and compensators
- submarine diesel engine exhaust systems
- superheater tubes in waste incineration plants
- cladding of waterwall sections and superheater tubes in waste incineration plants by overlay welding

### **Fabrication and heat treatment**

Nicrofer 6020 hMo can readily be hot- and cold worked and machined. Hot and cold working, however, require high-power machines, owing to the high strength of the material.

### **Heating**

Workpieces must be clean and free from all kinds of contaminants before and during any heat treatment.

Nicrofer 6020 hMo may become embrittled if heated in the presence of contaminants such as sulfur, phosphorus, lead and other low-melting-point metals. Sources of such contaminants include marking and temperature-indicating paints and crayons, lubricating grease, fluids and fuels.

Fuels must be as low in sulfur as possible. Natural gas should contain less than 0.1 wt.-% sulfur. Fuel oils with a sulfur content not exceeding 0.5 wt.-% are suitable.

Due to their close control of temperature and freedom from contamination, thermal treatments in electric furnaces under vacuum or an inert gas atmosphere are to be preferred. Treatments in an air atmosphere and alternatively in gas-fired furnaces are acceptable though, if contaminants are at low levels so that a neutral or slightly oxidizing furnace atmosphere is attained. A furnace atmosphere fluctuating between oxidizing and reducing must be avoided as well as direct flame impingement on the metal.

### **Hot working**

Nicrofer 6020 hMo may be hot worked in the temperature range 1150 to 900 °C (2100 to 1650 °F), followed by water quenching or rapid air cooling.

For heating up, workpieces may be charged into the furnace at maximum working temperature. When the furnace has returned to temperature, the workpieces should be soaked for 60 minutes per 100 mm (4 in.) of thickness. At the end of this period each workpiece should be withdrawn quickly and worked within the above temperature range. If the metal temperature falls below 950 °C (1740 °F), it must be reheated.

Heat treatment after hot working is recommended in order to achieve optimum properties and to ensure maximum corrosion resistance.

### **Cold working**

For cold working the material should be in the annealed condition. Nicrofer 6020 hMo has a higher work-hardening rate than austenitic stainless steels. This should be taken into account when selecting forming equipment. Interstage annealing may be necessary with high degrees of cold forming.

After cold working with more than 15% deformation a soft anneal is required before use. Also note the information on 'Relaxation cracking susceptibility'.

### **Heat treatment**

Nicrofer 6020 hMo (grade 1) is used in the soft-annealed condition. This thermal treatment is carried out in the temperature range 950 to 1050 °C (1740 to 1920 °F), preferably at about 980 °C (1800 °F).

A stabilizing anneal within a temperature range of > 900 °C and up to 1100 °C is generally carried out to improve resistance against intergranular corrosion particularly at welds during subsequent service under wet corrosive conditions. Its purpose is to modify finely distributed chromium carbides along grain boundaries formed during prior processing due to unfavourable thermal treatment conditions. This results in chromium depletion adjacent to the grain boundaries lowering in turn the alloy's corrosion resistance.

The stabilizing anneal causes the fine carbide precipitates to agglomerate to fewer, coarser, and rather more globular nodes which have a less adverse effect on wet corrosion resistance than finely divided carbides located almost completely on the grain boundaries. It also serves to remove any prior cold work which tends to accelerate carbide precipitation under unfavourable thermal treatment or service conditions. Higher carbon contents in stainless steels and Ni-Cr-(Mo)-alloys enhances carbide precipitation.

Furthermore, to reduce the incidence of chromium depletion, titanium or niobium is generally added to these alloys. These elements preferentially precipitate carbon as titanium or niobium carbides within the matrix rather than along the grain boundaries, thus further alleviating any danger of corrosion attack occurring.

A stabilizing anneal is similar to a soft anneal, but in contrast to the latter does not involve recrystallization of the grain structure.

Water quenching or rapid air cooling is recommended and is essential for maximum corrosion resistance.

**Stress-relief annealing** may be performed at temperatures up to the starting temperature of the soft-annealing temperature range. To avoid possible introduction of thermal stresses, the material should be slow cooled following stress-relief annealing. However, for materials which can be age hardened, stress-relief annealing may not result in the desired effect as stress-relief annealing followed by slow cooling takes place within the age-hardening temperature range and may thus lead to higher mechanical properties than would be encountered after soft annealing. As Nicrofer 6020 hMo – alloy 625 is one of the alloys which can age harden under certain conditions, it is recommended to ascertain the suitability of a stress-relief anneal by consultation with ThyssenKrupp VDM's Sales.

For any thermal treatment the material should be charged into the furnace at maximum annealing temperature, observing the precautions concerning cleanliness mentioned earlier under 'Heating'.

**Descaling and pickling**

Oxides of Nicrofer 6020 hMo and discoloration adjacent to welds are more adherent than on stainless steels. Grinding with very fine abrasive belts or discs is recommended. Care should be taken to prevent tarnishing.

Before pickling in a nitric/hydrofluoric acid mixture, the surface oxide layer must be broken up by abrasive blasting or grinding or by pretreatment in a fused salt bath. Particular attention should be paid to the pickling time and temperature.

**Machining**

Nicrofer 6020 hMo should be machined in the heat-treated condition. As the alloy is prone to work-hardening, a low cutting speed should be used and the tool should be engaged at all times.

An adequate depth of cut is important in order to cut below any previously formed work-hardened zone.

**Welding**

When welding nickel alloys, the following instructions should be adhered to:

**Workplace**

The workplace should be in a separate location, well away from the areas where carbon steel fabrication takes place. Maximum cleanliness and avoidance of draughts are paramount.

**Auxiliaries, clothing**

Clean fine leather gloves and clean working clothes should be used.

**Tools and machinery**

Tools used for nickel alloys and stainless steels must not be used for other materials. Brushes should be made of stainless materials.

Fabricating and working machinery such as shears, presses or rollers should be fitted with means (felt, cardboard, plastic sheeting) of avoiding contamination of the metal with ferrous particles, which can be pressed into the surface and thus lead to corrosion.

**Cleaning**

Cleaning of the base metal in the weld area (both sides) and of the filler metal (e. g. welding rod) should be carried out with ACETONE.

Trichlorethylene (TRI), perchlorethylene (PER), and carbon tetrachloride (TETRA) must not be used as they are detrimental to health.

**Edge preparation**

This should preferably be done by mechanical means by turning, milling or planing; abrasive water jet or plasma cutting is also possible. However, in the latter case the cut edge (the face to be welded) must be finished off cleanly. Careful grinding without overheating is permitted.

**Included angle**

The different physical characteristics of nickel alloys and special stainless steels compared with carbon steel generally manifest themselves in lower thermal conductivity and higher rate of thermal expansion.

This should be allowed for by means of, among other things, wider root gaps or openings ( $2 \text{ mm} \pm 0.5 \text{ mm}$ ), while larger included angles ( $60-70^\circ$ ), as shown in Fig. 3, should be used for individual butt joints owing to the viscous nature of the molten weld metal and to counteract the pronounced shrinkage tendency.



### Striking the arc

The arc should only be struck in the weld area, i. e., on the faces to be welded or on a run-out piece. Striking marks lead to corrosion.

### Welding process

Nicrofer 6020 hMo can be joined to itself and to many other metals by conventional welding processes. These include GTAW (TIG), plasma arc, GMAW (MIG/MAG and MAG-Tandem), SAW and SMAW (MMA). Pulsed arc welding is the preferred technique. For the MAG processes the use of a multi-component shielding gas (Ar+He+H<sub>2</sub>+CO<sub>2</sub>) is recommended.

For welding, Nicrofer 6020 hMo should be in the soft- or solution-annealed condition and be free from scale, grease and markings. When welding the root, care should be taken to achieve best-quality root backing (argon 99.99), so that the weld is free from oxides after welding the root. Any heat tint should be removed preferably by brushing with a stainless steel wire brush while the weld metal is still hot.

### Filler metal

For the gas-shielded welding processes, filler metal with the same composition as the base metal is recommended:

Bare electrodes: Nicrofer S 6020 – FM 625  
(W.-Nr. 2.4831)  
UNS N06625  
AWS A5.14: ERNiCrMo-3  
DIN EN ISO 18274: S Ni 6625  
(NiCr22Mo9Nb)

Covered electrodes: UNS W86112  
AWS A5.11: ENiCrMo-3  
DIN EN ISO 14172: E Ni 6625  
(NiCr22Mo9Nb)  
(W.-Nr. 2.4621)

For overlay welding by the electro-slag method (RES):

Welding wire or strip: Nicrofer S/B 6020 – FM 625/WS 625  
(W.-Nr. 2.4831)  
UNS N06625  
AWS A5.14: ERNiCrMo-3/EQNiCrMo-3  
DIN EN ISO 18274: S Ni 6625/B Ni 6625  
(NiCr22Mo9Nb)

### Welding parameters and influences (heat input)

Care should be taken that the work is performed with a deliberately chosen, low heat input as indicated in Table 8 by way of example. Use of the stringer bead technique should be aimed at. Interpass temperature should be kept below 150 °C (300 °F).

The welding parameters should be monitored as a matter of principle.

The heat input Q may be calculated as follows:

$$Q = \frac{U \times I \times 60}{v \times 1000} \text{ (kJ/cm)}$$

U = arc voltage, volts  
I = welding current, amps  
v = welding speed, cm/min.

Consultation with ThyssenKrupp VDM's Welding Laboratory is recommended.

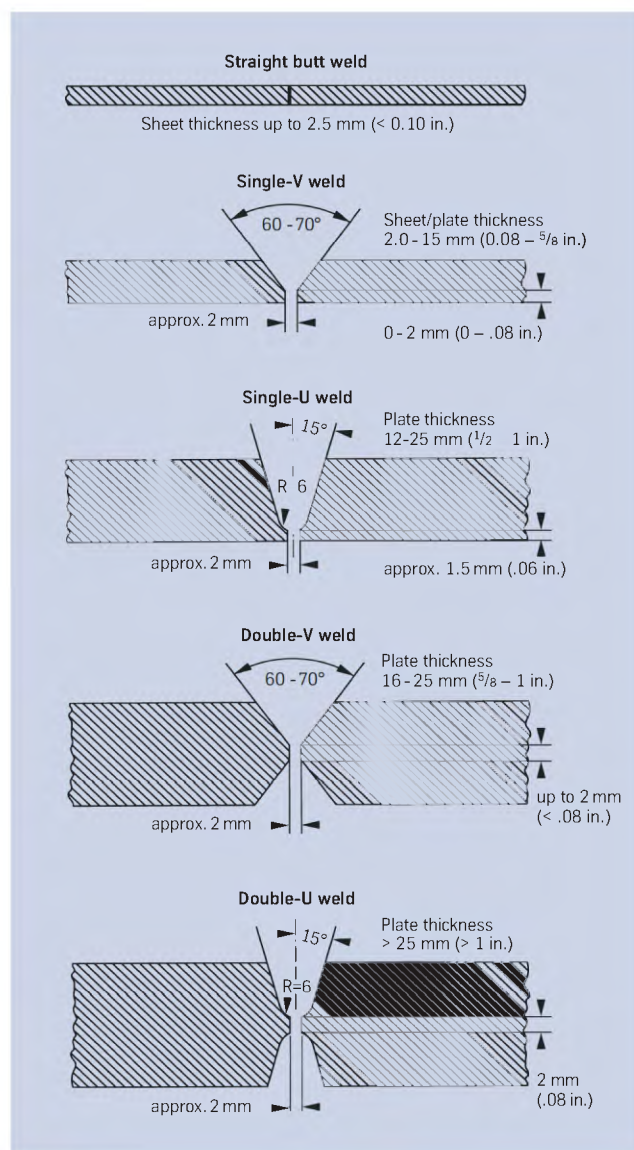

Fig. 3 – Edge preparation for welding of nickel alloys and special stainless steels.

# Nicrofer® 6020 hMo – alloy 625

Sheet/ plate thick- ness mm	Welding process	Filler metal		Welding parameters				Welding speed cm/min.	Shielding gas Type & rate l/min.	Plasma- gas Type & rate l/min.
		diameter mm	speed m/min.	Root pass		Intermediate and final passes				
				I A	U V	I A	U V			
3.0	Manual GTAW	2.0		90	10	110 – 120	11	approx. 15	Ar W3 <sup>1)</sup> 8 – 10	
6.0	Manual GTAW	2.0 – 2.4		100 – 110	10	120 – 140	12	14 – 16	Ar W3 <sup>1)</sup> 8 – 10	
8.0	Manual GTAW	2.4		100 – 110	11	130 – 140	12	14 – 16	Ar W3 <sup>1)</sup> 8 – 10	
10.0	Manual GTAW	2.4		100 – 110	11	130 – 140	12	14 – 16	Ar W3 <sup>1)</sup> 8 – 10	
3.0	Autom. GTAW	1.2	approx. 1.2	Manual GTAW		150	11	25	Ar W3 <sup>1)</sup> 12 – 14	
5.0	Autom. GTAW	1.2	approx. 1.4	Manual GTAW		180	12	25	Ar W3 <sup>1)</sup> 12 – 14	
2.0	Hot wire GTAW	1.0				180	11	80	Ar W3 <sup>1)</sup> 12 – 14	
10.0	Hot wire GTAW	1.2		Manual GTAW		220	12	40	Ar W3 <sup>1)</sup> 12 – 14	
4.0	Plasma arc	1.2	approx. 1.0	approx. 180	25			30	Ar W3 <sup>1)</sup> 30	Ar 4.6 3.0
6.0	Plasma arc	1.2	approx. 1.0	200 – 220	26			26	Ar W3 <sup>1)</sup> 30	Ar 4.6 3.5
8.0	GMAW (MIG/MAG <sup>2)</sup> )	1.0	6 – 7	Manual GTAW		130 – 140	23 – 27	24 – 30	Ar 4.6 <sup>2)</sup> 18	
10.0	GMAW (MIG/MAG <sup>2)</sup> )	1.2	6 – 7	Manual GTAW		130 – 150	23 – 27	25 – 30	Ar 4.6 <sup>2)</sup> 18	
6.0	SMAW (MMA)	2.5		40 – 70	approx. 21	40 – 70	approx. 21			
8.0	SMAW (MMA)	2.5 – 3.25		40 – 70	approx. 21	70 – 100	approx. 22			
16.0	SMAW (MMA)	4.0				90 – 130	approx. 22			

<sup>1)</sup> Argon or argon + max. 3% hydrogen

<sup>2)</sup> For MAG welding the use of the multi-component shielding gas Cronigon Ni10, for example, is recommended.

In all gas-shielded welding operations, ensure adequate back shielding with Ar 4.6 (pure argon).

Figures are for guidance only and are intended to facilitate setting of the welding machines.

Table 7 – Welding parameters (guide values).

Welding process	Heat input per unit length kJ/cm	Welding process	Heat input per unit length kJ/cm
GTAW, manual, fully mechanised	max. 8	GMAW, MIG/MAG, manual, fully mechanised	max. 8
Hot wire GTAW	max. 6	SAW	max. 10
Plasma arc	max. 10	SMAW, manual metal arc (MMA)	max. 7

Table 8 – Heat input per unit length (guide values).

### Postweld treatment

(brushing, pickling and thermal treatments)

Brushing with a stainless steel wire brush immediately after welding, i.e., while the metal is still hot generally results in removal of heat tint and produces the desired surface condition without additional pickling.

Pickling, if required or prescribed, however, would generally be the last operation performed on the weldment. Also refer to the information under 'Descaling and pickling'.

Neither pre- nor postweld thermal treatments are normally required. However, to eliminate the risk of relaxation cracking of material exposed to service temperatures within the range of 625 – 675 °C (1160 – 1250 °F), following cold working and/or (repair) welding, the PWHT recommendations given under 'Relaxation cracking susceptibility' should be adhered to.

### Availability

Nicrofer 6020 hMo is available in the following standard product forms:

#### Sheet & plate

(for cut-to-length availability, refer to strip)

Conditions:

hot or cold rolled (hr, cr),  
thermally treated and pickled

Thickness mm	hr / cr	Width <sup>1)</sup> mm	Length <sup>1)</sup> mm
1.00 – < 2.00	cr	1000 – 2400	10,000
2.00 – < 8.00	cr/hr	2500	10,000
8.00 – ≤ 25.00	hr	2500	10,000
> 25.00 <sup>1)</sup>	hr	2500 <sup>2)</sup>	10,000 <sup>2)</sup>

inches		inches	inches
0.040 – < 0.080	cr	40 – 95	395
0.080 – < 0.310	cr/hr	100	395
0.310 – ≤ 1.000	hr	100	395 <sup>2)</sup>
> 1.000 <sup>1)</sup>	hr	100 <sup>2)</sup>	395 <sup>2)</sup>

<sup>1)</sup> other sizes subject to special enquiry

<sup>2)</sup> maximum piece weight: 2700 kg (6000 lbs);  
up to 4500 kg (9900 lbs) subject to special enquiry

### Discs and rings

Conditions:

hot rolled or forged,  
thermally treated,  
descaled, pickled or machined

Product	Weight kg	Thickness mm	O. D. <sup>1)</sup> mm	I. D. <sup>1)</sup> mm
Disc	≤ 10000	≤ 300	≤ 3000	
Ring	≤ 3000	≤ 200	≤ 2500	on request

	lbs	inches	inches	inches
Disc	≤ 22000	≤ 12	≤ 120	
Ring	≤ 6600	≤ 8	≤ 100	on request

<sup>1)</sup> other sizes subject to special enquiry

### Rod & bar

Conditions:

forged, rolled, drawn,  
thermally treated,  
descaled, pickled, machined, peeled or ground

Product	Forged <sup>1)</sup> mm	Rolled <sup>1)</sup> mm	Drawn <sup>1)</sup> mm
Rod (O. D.)	≤ 600	7 – 120	8 – 75
Bar, square (a)	40 – 500	15 – 280	not standard
Bar, flat (a x b) <sup>2)</sup>	(40 – 80) x (200 – 600)	(5 – 20) x (120 – 600)	not standard
Bar, hexagonal (s) <sup>2)</sup>	40 – 80	13 – 41	≤ 50

	inches	inches	inches
Rod (O. D.)	≤ 24	$\frac{5}{16}$ – $4\frac{3}{4}$	$\frac{5}{16}$ – 3
Bar, square (a)	$1\frac{5}{8}$ – 20	$\frac{10}{16}$ – 11	not standard
Bar, flat (a x b) <sup>2)</sup>	( $1\frac{5}{8}$ – $3\frac{1}{8}$ ) x (8 – 24)	( $\frac{3}{16}$ – $\frac{3}{4}$ ) x ( $4\frac{3}{4}$ – 24)	not standard
Bar, hexagonal (s) <sup>2)</sup>	$1\frac{5}{8}$ – $3\frac{1}{8}$	$\frac{1}{2}$ – $1\frac{5}{8}$	≤ 2

<sup>1)</sup> other sizes subject to special enquiry

<sup>2)</sup> subject to special enquiry

### Forgings

Shapes other than discs, rings, rod and bar are subject to special enquiry. Flanges and hollow shafts may be available up to a piece weight of 10 t.



**Strip<sup>1)</sup>**

Conditions:  
cold rolled,  
thermally treated and pickled or bright annealed<sup>2)</sup>

Thickness mm	Width <sup>3)</sup> mm	Coil I. D. mm			
0.02 – ≤ 0.10	4 – 200 <sup>4)</sup>	300	400		
> 0.10 – ≤ 0.25	4 – 720 <sup>4)</sup>	300	400	500	
> 0.25 – ≤ 0.60	6 – 750		400	500	600
> 0.60 – ≤ 1.0	8 – 750		400	500	600
> 1.0 – ≤ 2.0	15 – 750		400	500	600
> 2.0 – ≤ 3.0	25 – 750		400	500	600

inches	inches	inches			
0.0008 – ≤ 0.004	0.16 – 8 <sup>4)</sup>	12	16		
> 0.004 – ≤ 0.010	0.16 – 28.5 <sup>4)</sup>	12	16	20	
> 0.010 – ≤ 0.024	0.24 – 30		16	20	24
> 0.024 – ≤ 0.040	0.32 – 30		16	20	24
> 0.040 – ≤ 0.080	0.60 – 30		16	20	24
> 0.080 – ≤ 0.120	1.0 – 30		16	20	24

<sup>1)</sup> cut-to-length available in lengths from 250 to 4000 mm (10 to 158 in.)

<sup>2)</sup> Maximum thickness: bright annealed -3 mm (0.120 in.)  
cold rolled only -3.5 mm (0.140 in.)

<sup>3)</sup> Wider widths are subject to special enquiry

<sup>4)</sup> Wider widths up to 730 mm (29 in.) are subject to special enquiry

**Wire**

Conditions:  
shaved; bright drawn, 1/4 hard to hard;  
bright annealed

**Dimensions:**

0.15 – 19.0 mm (0.006 – 0.75 in.) diameter,  
in coils, pay-off packs, on spools and spiders.

Other dimensions as well as flat and contoured wire  
are subject to special enquiry.

**Welding filler metals**

Suitable welding rods, wire and electrode core wire are  
available in standard sizes.

**Seamless tube and pipe**

Using ThyssenKrupp VDM cast materials seamless tubes  
and pipes are produced and may be available from Mannes-  
mann DMV STAINLESS Deutschland GmbH, Wiesenstr. 36,  
D-45473 Mühlheim/Ruhr; Tel.: +49 208 458-2611;  
Fax: +49 208 458-2641;

Email: salesgermany@dmv-stainless.com;

Internet: www.mannesmann-dmv.com

**Welded tube and pipe**

Welded tubes and pipes are obtainable from qualified manu-  
facturers using ThyssenKrupp VDM semi-fabricated products.

**Technical publications**

The following publications concerning Nicrofer 6020 hMo –  
alloy 625 may be obtained from ThyssenKrupp VDM GmbH:

U. Brill, U. Heubner, M. Rockel:

Hochtemperaturkorrosion handelsüblicher hochlegierter  
austenitischer Werkstoffe im geschweißten und  
ungeschweißten Zustand;

Metall 44 (1990) p. 936 – 946

U. Brill, U. Heubner, K. Drehfahl, J. Henrich:

Zeitstandwerte von Hochtemperaturwerkstoffen;  
Ingenieurwerkstoffe 3 (1991) Nr. 4, p. 59 – 62

M. Köhler:

Effect of Elevated-Temperature-Precipitation in Alloy 625 on  
Properties and Microstructure, Superalloys 718, 625 and  
Various Derivates;

TMS (1991) p. 363 – 374

U. Heubner, M. Köhler:

Das Zeit-Temperatur-Ausscheidungs- und das Zeit-  
Temperatur-Sensibilisierungs-Verhalten von hochkorro-  
sionsbeständigen Nickel-Chrom-Molybdän-Legierungen;  
Werkstoffe und Korrosion 43 (1992), p. 181 – 190

U. Heubner, M. Köhler:

Effect of Carbon Content and Other Variables on Yield  
Strength, Ductility and Creep Properties of Alloy 625,  
Superalloys 718, 625, 706 and Various Derivates;

TMS (1994) p. 479 – 488

M. Köhler, U. Heubner:

Time-Temperature - Sensitization and  
Time-Temperature - Precipitation

Behaviour of Alloy 625;

CORROSION '96, Paper No. 427, NACE International,  
Houston, Texas, 1996

*The information contained in this data sheet is based on results of research and development work and data listed in applicable specifications and standards available and in effect at the time of printing. It does not provide any guarantee of particular characteristics or fit. ThyssenKrupp VDM reserves the right to make changes without notice. The data sheet has been compiled to the best knowledge of ThyssenKrupp VDM and is given without any liability on the part of ThyssenKrupp VDM. ThyssenKrupp VDM is only liable according to the terms of the sales contract and in particular to the General Conditions of Sales in case of any delivery from ThyssenKrupp VDM.*

*As updates of data sheets are not automatically sent out, when issued, ThyssenKrupp VDM recommends to request the latest edition of required data sheets either by phone +49 2392 55-2588, by fax +49 2392 55-2596 or by Email under vdm@thyssenkrupp.com.*

*Current issues of brochures and data sheets are also available in the Internet under www.thyssenkruppvd.com.*

*August 2007 Edition.*

*This edition supersedes material data sheet no. 4018, dated June 2002.*



Nicrofer

602

**ThyssenKrupp VDM GmbH**  
Plettenberger Strasse 2  
58791 Werdohl  
P.O. Box 18 20  
58778 Werdohl  
Germany  
Phone: +49 2392 55-0  
Fax: +49 2392 55-2217  
Email: [vdm@thyssenkrupp.com](mailto:vdm@thyssenkrupp.com)  
[www.thyssenkruppvdm.com](http://www.thyssenkruppvdm.com)

**QUEENSLAND AGENT:**  
**Isolthermics Australia Pty Ltd**  
**Phone: 07 3245 5561**  
**Fax: 07 3245 4753**  
**Email: [info@isolthermics.com.au](mailto:info@isolthermics.com.au)**  
**Web: [www.isolthermics.com.au](http://www.isolthermics.com.au)**